

How does Transformational Leadership Influence Creativity Through Job Satisfaction?

Rizky Kurnia Hidayat^{1*}, Heru Kurnianto Tjahjono²

^{1*}Correspondence Author: rizkykurniaa@gmail.com

^{1,2} Management Department, Faculty of Business and Economics, Universitas Muhammadiyah Yogyakarta, Indonesia

INFO

Article History

Received:
2023-07-16
Revised:
2023-08-23
Accepted:
2023-08-14

ABSTRACT

This research examined how transformational leadership affects creativity through job satisfaction. This study focuses on elementary school teachers as the research subject. A total of 10 elementary schools were selected as the population for the study. This study utilized a total sampling technique, involving all the teachers who work in the ten selected elementary schools as the research participants. In this study, 147 questionnaires were distributed, of which 130 questionnaires completed by teachers were considered usable. This study employed the AMOS 22 application program as the analytical tool for conducting Structural Equation Modelling (SEM) analysis. The analysis revealed that transformational leadership did not directly impact creativity. Transformational leadership had a positive and significant effect on job satisfaction. Job satisfaction had a positive and significant effect on creativity. Transformational leadership positively and significantly affected creativity through job satisfaction with a full mediation. The result has practical and meaningful implications for elementary school principals in fostering teachers' creativity through transformational leadership and job satisfaction.



This work is licensed under [Attribution-NonCommercial-NoDerivatives 4.0 International](https://creativecommons.org/licenses/by-nc-nd/4.0/)

Keywords: Transformational Leadership; Creativity; Job Satisfaction

INTRODUCTION

Elementary education aims to develop fundamental intelligence, knowledge, personality, noble character, and skills for independent living. Based on these goals, elementary teachers' duties are challenging as they are expected to think creatively. They are responsible for imparting knowledge and shaping a strong foundation of character for their students. However, this expectation can sometimes burden elementary school teachers and adversely affect their psychological well-being, impacting job satisfaction. Creativity in learning is integral to the relationship between educators and students in education and teaching. A teacher's creativity is not limited to facilitating the teaching-learning process within a single dimension of human development but also involves other aspects, such as cognitive, psychomotor, and affective domains (Oktavia, 2014). Creativity also plays a significant role in influencing academic performance and enhancing education quality. Nevertheless, due to the diverse skills of students, the teaching process necessitates teachers to employ innovative approaches (such as methods, time management, and simplification of materials) to stimulate motivation, improve the learning process, and achieve high-quality learning outcomes (Tamsah et al. 2021). School creativity can

be nurtured by consistently enhancing the children's environment, which involves creating creative programs to encourage innovative thinking across various subjects (Khalid et al., 2020).

The demand for creative educators is currently a significant global concern. Many countries are engaged in extensive discussions and initiatives, both within and outside the teaching profession, to highlight the increasing importance of supporting teachers in fostering creative learning and nurturing the creativity of young individuals (Borodina et al., 2019). Consequently, society requires innovative educators who can discover novel approaches to tackle professional challenges, cater to student's individual needs, possess a creative drive, and demonstrate the capability to develop unconventional solutions. (Borodina et al., 2019). Currently, the role of a teacher has shifted from being a central figure in the learning process to being a facilitator. Teachers must be able to guide students, encouraging active participation and critical thinking in their learning. This approach prevents students from feeling bored or disengaged by solely listening to the teachers' explanations. Utilizing engaging learning models becomes essential to captivate students' interest and stimulate their active and creative thinking during the learning process (Hobri et al., 2020).

Teachers can incorporate creative teaching techniques, but becoming competent requires gradual and extensive development. Even with sufficient educational qualifications, cultivating creativity and employing creative methods demand additional experience, skills, and knowledge. Training is a prevalent approach, but effective management must yield positive outcomes. Practical training is essential for producing high-quality teachers and fostering excellent creativity in the long run (Tamsah et al., 2021). Leaders, or in this case, elementary school principals, can play a vital role in determining employees' or subordinates' creative behavior. To encourage creative behavior, a leader can enhance their subordinate's capabilities by empowering and supporting them to succeed, thus increasing their confidence in utilizing available resources. Similarly, transformational leaders prioritize boosting their subordinate's self-esteem and belief in themselves by expressing trust, setting high-performance standards, and motivating them to exhibit creativity. Consequently, subordinates working under transformational leaders are more likely to be highly effective as they establish clear objectives and provide support and empowerment to help their followers accomplish them (Jaiswal & Dhar, 2016).

The phenomenon observed indicates that, in general, the teaching behavior of elementary school teachers is limited to the understanding of teaching as a one-way process from the teacher to the students. As a result, the learning experience often becomes monotonous, less engaging, and lacking motivation, leading to a tendency for students to adopt a passive attitude. Creating creativity that aligns with students' personalities requires additional training and effort, indirectly burdening teachers and affecting job satisfaction. Therefore, good leadership management is needed to regulate the behavior and job satisfaction of the employees. Combining transformational leadership and job satisfaction, educational institutions can create an environment that nurtures and celebrates teachers' creativity. It benefits students as they experience more engaging and effective learning experiences, leading to improved academic outcomes and a positive school atmosphere.

LITERATURE REVIEW

Transformational Leadership

Tjahjono et al. (2018) defined leadership as influencing and convincing others to recognize, comprehend, and align their perspective with the tasks and methods to accomplish them. Kharis (2015) defined transformational leadership as a leadership style that inspires followers to transcend personal interests and possesses exceptional influencing capabilities. The key aspect of transformational leadership is the emphasis on development and growth. Transformational leadership significantly influences and empowers its members to achieve desired outcomes. The key focal point in transformational leadership is vision. Vision in this context serves as a guide for a leader to drive change. Without a clear vision, leaders cannot transform an organization and inspire their employees (Ripki et al., 2020).

Bas (1999) stated that transformational leadership elevates followers' enthusiasm, motivation, and morality. Transformational leadership increases employees' awareness of what is more important and increases awareness of achievement and self-actualization. Leaders set an example for their employees to prioritize the well-being of the group and organizations over individuals. Leadership is the interaction between two or more group members, often involving the alignment of perceptions and expectations among the members. Leadership occurs when one group member (the leader) inspires and enhances the motivation or competence of others within the group (Bass, 1999). Transformational leadership can positively impact the future; employees will feel admiration, loyalty, respect towards their leader, trust, and motivation to carry out their jobs beyond what was initially expected (Sudjijana, 2020). A leader is an individual who provides significance and influence on an organization, potentially holding a central role (Tjahjono, 2004). The transformative capability refers to the ability to foster innovation and empower followers, encouraging a shift in their mindset and comprehension of organizational objectives, ultimately making them feel engaged and accountable in accomplishing their tasks. Bass and Sillin (in Jufrizen, 2017) stated that transformational leadership has four characteristics.

Charisma is a highly important component in transformational leadership. A charismatic leader should possess high self-confidence, strong beliefs, strong idealism, and the ability to influence others. Leaders with charisma generally earn their followers' love, and even the followers feel confident and trust each other under charismatic leadership. For a charismatic leader, followers always perceive their leader as an ideal role model, fostering enthusiasm among their followers and enabling them to work happily. The charisma scale in transformational leadership depicts the extent to which a leader creates enthusiasm among their followers and can discern what truly matters. Through charisma, leaders can inspire loyalty and dedication, instill a sense of pride and loyalty, and share a feeling of respect.

Individual consideration means every transformational leader recognizes the importance of individual factors that can be reconciled despite differences in interest and personal development. Transformational leaders will pay attention to individual factors as they should not be treated equally, considering the differences in social background, culture, and personal

development. Thus, a leader will provide attention to nurture, guide, and train individuals according to their unique characteristics.

Intellectual stimulation is a leader's ability to create, interpret, and develop symbols that emerge in life and encourage followers to think critically. Thus, followers are motivated to constantly question themselves and develop independent problem-solving skills in each situation.

Inspiration characteristics are a leader's effort to provide meaning and challenges to followers to boost their morale and hope. Transformational leaders aim to provide inspiring motivation to those around them. The leaders' behavior can generate enthusiasm among followers for group tasks and effectively express words that build trust in their abilities to accomplish tasks and achieve group goals.

In addition, a teacher requires a transformative leader who can provide guidance and motivation to inspire teachers to discover new ideas in teaching and learning. With leadership that can motivate and serve as an example for teachers, discovering ideas becomes easy, and creativity will increase.

Job Satisfaction

Tjahjono (2015) referred to job satisfaction as how employees feel about their work or various aspects. Job satisfaction is of high importance to both the organization and its employees. Job satisfaction is a positive feeling that results from evaluating various job characteristics. Individuals with high job satisfaction have positive feelings toward their work. In contrast, those with low job satisfaction have negative feelings toward their work (Robbins, 2012). Building job satisfaction includes providing financial and non-financial intrinsic rewards, such as rewards related to social support. Another intrinsic reward is empowering employees to find meaning in their work (Palupi & Tjahjono, 2021).

Job satisfaction represents an emotional stance held by individuals regarding their work. Multiple factors, such as salary, the intrinsic nature of the job, supervision, working conditions, and interactions with colleagues, impact this emotional aspect. Job satisfaction significantly affects an individual's work outcome, particularly their creativity. When someone experiences contentment and comfort in their work, they are more likely to exhibit enthusiasm for task performance, ultimately boosting their creativity (Ripki et al., 2020). Job satisfaction is an individual's feelings toward their job, work situation, and colleague relationship. Therefore, an employee should possess job satisfaction to interact effectively within their work environment (Haryadi et al., 2022). Specto (1997) stated that job satisfaction consists of nine characteristics.

Pay can be defined as a salary that is an important indicator of job satisfaction. Employees who feel fairly compensated according to their contribution and responsibilities are more satisfied with their jobs.

Promotion is an opportunity for advancement in the workplace and can also affect job satisfaction. Employees who see the possibility of promotion and career growth tend to feel more engaged and satisfied with their work.

Supervision in the workplace can influence job satisfaction. Employees who feel supported by their supervisors and receive clear guidance and constructive feedback tend to feel more satisfied doing their tasks.

Fringe benefits are additional benefits the company provides to employees, such as health benefits, flexible leave, and retirement programs, and can also impact job satisfaction. Employees who receive adequate fringe benefits tend to feel valued and satisfied with their jobs.

Contingent rewards refer to employee recognition and rewards because of their achievements or good performance. Employees who perceive these rewards as fair and proportional to their efforts tend to feel motivated and satisfied with their jobs.

Operating conditions refer to good working conditions, such as a comfortable work environment, adequate facilities, and proper equipment, which can contribute to job satisfaction. Employees working in supportive conditions tend to feel more comfortable and satisfied performing their tasks.

Coworkers are also a crucial factor in job satisfaction. Employees with good working relationships, a cohesive team, and social support in the workplace tend to feel more satisfied and engaged.

The nature of work or the job itself can also influence job satisfaction. Employees tend to feel more satisfied and fulfilled if the job provides adequate challenges, opportunities for learning skill development, and a sense of meaningful tasks.

Communication is good communication between management and employees and is essential for job satisfaction. Employees need to feel heard, involved in decision-making, and provided with clear and timely information. Effective communication can enhance job satisfaction by creating a sense of understanding and support in the workplace.

Creativity

Palupi (2020) stated that employees who possess creativity are expected to provide creative ideas to enhance their and the organization's performance. By fostering creativity and sharing it with other employees, the organization encourages participation in innovation, ultimately leading to a competitive advantage. Creativity generates something new and combines old and new ideas, resulting in something creative (Ripki et al., 2020). Creativity is an individual ability to correctly create or produce something new or original that was previously unknown or to solve new problems encountered. On the other hand, a teacher manages the teaching and learning process. Therefore, teacher creativity is the ability of a teacher to create new things in teaching, providing variations in teaching methods that will make students more active and creative (Oktavia, 2014). The characteristics of a creative teacher include being flexible, optimistic, respectful, agile, humorous, inspiring, gentle, disciplined, responsive, and empathetic (Pardamean, 2009).

Ayranci (2017) defined creativity as primarily based on the uniqueness of individuals in generating and pursuing their ideas. It also involves their confidence in their instinct and agility to switch between various methods and solutions to overcome problems. Teacher creativity plays a crucial role in enhancing students' interest in subjects. One form of implementing

teacher creativity is through instruments that connect learning with the real world, such as visualization. This approach reduces students' boredom, increasing their interest in the subject matter (Talajan, 2012).

Oktavia (2014) stated that the factors influencing teacher creativity are internal factors, heritage, psychological and external factors, and social and cultural environment. Internal factors are inherent to human nature, with an inherent drive to develop and grow towards better endeavors, following their cognitive abilities to meet their needs. Similarly, in carrying out their educational responsibilities, a teacher desires personal growth and development towards a better and higher quality. On the other hand, external factors influence their surroundings, such as the environment in which they live and interact. As an educator, teachers are expected to be more creative than students. The importance of creativity for students highlights the significance of creativity for teachers as well.

Hypotheses Development

Teachers require a transformative leader who can provide guidance and motivation to inspire teachers to discover new ideas in teaching and learning. With leadership that can motivate and serve as an example for teachers, discovering ideas becomes easy, and creativity will increase. Al-Ghazali et al. (2022), Jaiswal & Dhar (2016), Ayranci (2017), Burhanudin et al. (2022), Wijayanti & Supartha (2019), Malau & Sianipar (2019), Minh-Duc & Huu-Lam, (2019) revealed that transformational leadership had a positive influence on creativity. Thus, the hypothesis is arranged based on the theory and logic and previous studies conducted.

H1: Transformational leadership has a positive influence on creativity.

Transformational leadership creates an environment that can motivate employees to achieve organizational goals and develop a passion for their work. Salau et al. (2018), Sunaryo et al. (2023), Palguna & Supartha (2016), Diansya (2018), Kim & Lee (2011), (Ripki et al. (2020) found that transformational leadership had a positive influence on job satisfaction. Thus, the hypothesis is arranged based on the theory and logic and previous studies conducted.

H2: Transformational leadership has a positive influence on job satisfaction.

Ideally, the needs of employees, both material and psychological, should always be considered to create satisfaction in their work. When job satisfaction is achieved, individuals are likelier to channel greater effort into their work. Previous studies conducted by (Puji Astuti et al. (2019), Andrian (2017), Praman (2017), Spanjol et al. (2015), and Anggarwati & Eliyana (2015) revealed that job satisfaction had a positive influence on creativity. Thus, the hypothesis is arranged based on the theory, logic, and previous studies conducted.

H3: Job satisfaction has a positive influence on creativity.

Transformational leaders can help followers better understand their work and facilitate a shared sense of purpose that enhances job satisfaction. When employees or teachers are satisfied with their work and job requirements, they are more likely to be motivated to generate new ideas

and find new solutions. Fareed et al. (2022), Kim & Lee (2011), and Sofyan & Rianty Mardina (2023) found that job satisfaction positively mediated the influence of transformational leadership on creativity. Thus, the hypothesis is arranged based on the theory and logic and previous studies conducted.

H4: Job satisfaction positively mediates the influence of transformational leadership on creativity.

Research Model

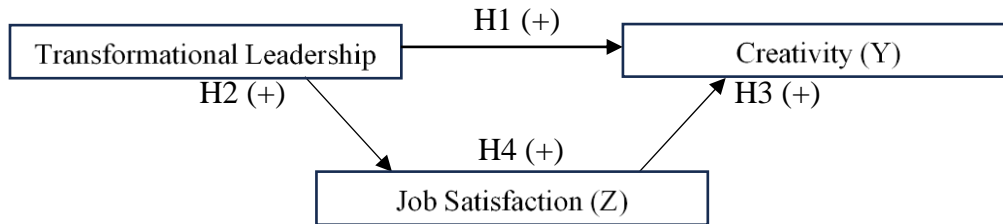

Picture 1. Research Model

RESEARCH METHOD

The research method employed in this study followed quantitative research. The type of data in this research includes primary data, which refers to data obtained directly from respondents or data sources. Data was collected through questionnaires. The population in this study consists of 130 teachers from 10 elementary schools. The sample to be studied in this research will utilize the entire population of 130 teachers. Therefore, this sampling technique is referred to as total sampling.

Definition of Operational Variable

Transformational Leadership

Transformational leadership refers to the act of influencing and convincing others to recognize, comprehend, and align their perspective with the tasks at hand and the methods to accomplish them (Tjahjono et al., 2018)

Job Satisfaction

Job satisfaction relates to how an individual perceives their work and the different aspects of their job. In other words, job satisfaction is a progression beyond simply feeling satisfied or dissatisfied with one's work (Spector, 1997).

Creativity

Employee creativity refers to the generation of ideas by employees related to new products, services, practices, and procedures, which can bring advantages to the organization and the company (Zhou & George 2001).

RESULTS AND DISCUSSION

Validity Test

Testing the instrument's validity was seen from construct validity by calculating the correlation between each measurement tool, an indicator considered valid the value of the standardized loading estimate is greater than 0.50. Validity was shown that all instruments are greater than 0.50. Thus, all instruments were valid.

Reliability Test

Reliability measure using construct reliability, an instrument considered reliable when the accepted threshold value for construct reliability is above 0.7. In this research, the reliability construct showed that all the variables were above 0.7; thus, the whole item was consistent.

Table 1. Reliability result

Variables	CR	Cut-off	Explanation
Transformational leadership	0,916	≥0.7	Reliable
Job satisfaction	0,915		Reliable
Creativity	0,933		Reliable

Respondent Characteristic

Respondent data showed that 44% of respondents are between 41 and 50. Based on gender, it consists of 48 males with 36% and 82 females with 63%.

Table 2. Distribution of respondents based on age

Category	Frequency	Percentage
Genders		
Man	48	36.9%
Woman	82	63.0%
Total	130	100%
Ages		
20 – 25 years old	10	7.6%
26 – 30 years old	17	13.0%
31 – 35 years old	21	16.1%
36 – 40 years old	24	18.4%
41 – 50 years old	58	44.6%
Total	130	100%

Descriptive Data Statistic

Descriptive statistical analysis aims to provide an overview of each variable being tested with descriptive variables. Based on the collected data, the average of each respondent from interval-class variables with five classes will be obtained. The descriptive analysis can be seen in Table 3.

Table 3. Descriptive data related to the answers of respondents.

No.	Variable	Mean
1	Transformational leadership	4.37
2	Job satisfaction	4.27
3	Creativity	3.38

In general, the three variables of transformational leadership, job satisfaction, and creativity were perceived by high and high respondents.

Normality Test

The assessment of normality was performed on the data set employed for the comprehensive analysis of the initial model, utilizing AMOS version 22. In the output of AMOS version 22, normality can be assessed through the values of data distribution skewness and kurtosis. If the CR value falls within the range of -2.58 to 2.58 (± 2.58) at a significant level of 1%, the data follows a normal, univariate, and multivariate distribution. The multivariate value in this study stands at 0.583, indicating that this value falls within the range of ± 2.58 . Therefore, it can be concluded that the normality assumption is met, and the data is normally distributed.

Goodness of Fit Test

Table 4. Goodness of Fit Result

Goodness of Fit Index	Cut off Value	Result	Index Criteria
Chi-square	X2 with df =492 Value is 544,7088	681,020	Rejected
X2 Significance Probability	$\geq 0,05$	0,000	Rejected
CMIN/DF	$\leq 2,00$	1,384	Good/Fit
TLI	$\geq 0,90$	0,864	Acceptable
CFI	$\geq 0,90$	0,873	Acceptable
IFI	$\geq 0,90$	0,876	Acceptable
RMR	$\leq 0,05$	0,040	Good/Fit
RMSEA	$\leq 0,08$	0,055	Good/Fit

Brownee and Cuddeck in (Tjahjono et al., 2021) stated that an RMSEA value of $\leq 0,08$ constitutes an index for accepting a research model that demonstrates a close fit of the model based on degrees of freedom. In this research model, RMSEA has fitting criteria.

Hypothesis Test

Hypothesis testing was conducted to answer the research questions or analyze relationships within the structural model. Hypothesis data analysis can be observed through regression weight values, which reflect the influence coefficients between variables.

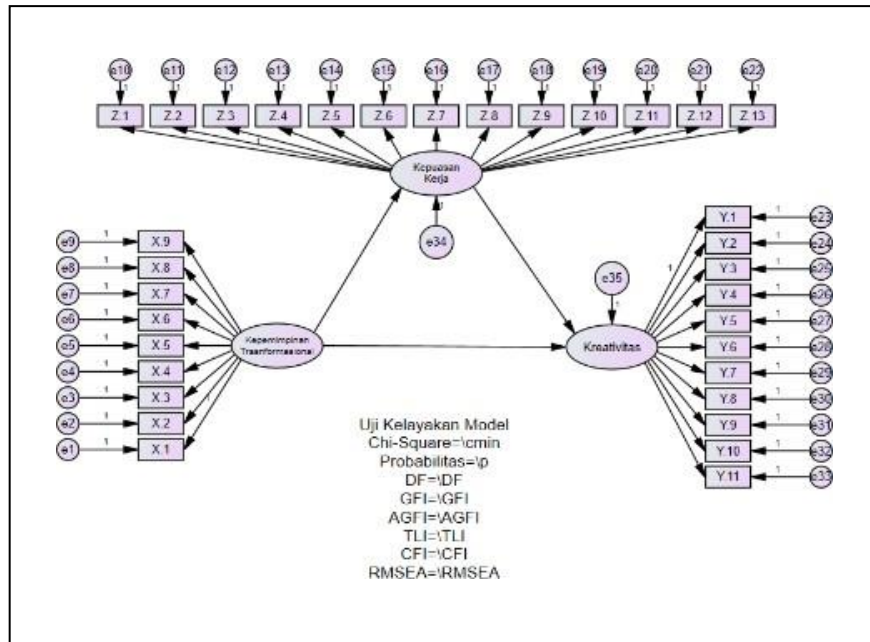

Picture 1. Structural Model AMOS

Table 5. Regression weight analysis

		estimate	SE.	CR.	P	Hypothesis
Transformational leadership	Job satisfaction	0,780	0,152	5,145	0,000	Accepted
Transformational leadership	Creativity	-0,430	0,261	-1840	0,066	Rejected
Job satisfaction	Creativity	0,599	0,278	2,155	0,031	Accepted

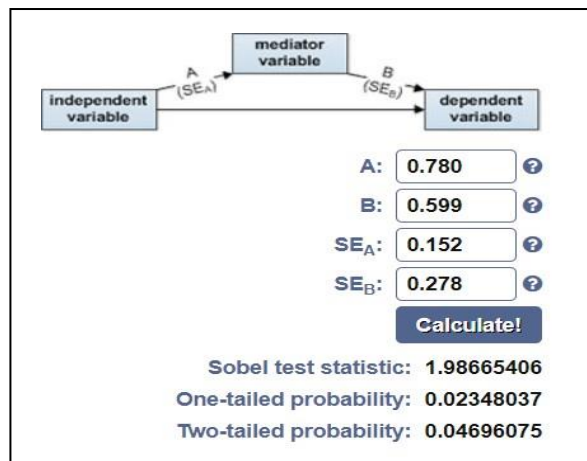

Picture 2. Sobel test for mediating variable

Transformational Leadership on Creativity

The estimated value of the coefficient output from the regression weight for this variable has a p-value of 0.066, greater than 0.05. Also, CR from the regression weight is -1840, which

is lower than 1,960. Therefore, no significant influence of transformational leadership on creativity was found, meaning that 130 teachers in the 10 elementary schools may not feel motivated or inspired to generate new ideas or develop creative approaches to teaching. This issue can limit the potential for innovation and educational advancement within the classroom. Effective transformational leadership typically enhances teachers' motivation to achieve better results.

Nevertheless, the absence of transformational leadership influence can harm teacher motivation. Teachers might feel less motivated to innovate and generate new creative ideas to improve the quality of their teaching. However, understanding that transformational leadership does not significantly influence teachers' creativity can provide valuable insights for improving and developing more effective leadership strategies to enhance teachers' creativity in the future.

Transformational Leadership on Job Satisfaction

The estimated value of the coefficient output from the regression weight for this variable had a p-value of 0.000, which is less than 0.05. Also, CR from the regression weight was 5,145, greater than 1,960. Therefore, a significant influence of transformational leadership on 130 teachers' job satisfaction was revealed. Transformational leadership encourages active participation in teachers' decision-making and activity planning. Teachers feel empowered and will be held responsible for developing and advancing the learning process. They can provide a higher sense of involvement and, in turn, enhance their job satisfaction. Effective transformational leadership creates an environment where teachers feel motivated and acknowledged for their contributions. Transformational leadership also often involves mentorship and individual potential development. Teachers who receive support and opportunities to enhance their skills and competencies tend to feel more satisfied with their work. They will enhance their job satisfaction as they feel valued and provided with growth opportunities. This finding demonstrates the importance of leaders in creating a motivating and supportive environment for teacher development, which ultimately enhances their job satisfaction.

Job Satisfaction on Creativity

The estimated value of the coefficient output from the regression weight for this variable had a p-value of 0.031, which is less than 0.05. Also, CR from the regression weight is 2,155, greater than 1,960. Therefore, a significant influence of job satisfaction on 130 teachers' creativity was found. When teachers feel satisfied with their work, they are more likely to be motivated and actively engaged in learning. High job satisfaction provides intrinsic and extrinsic incentives that motivate teachers to generate creative ideas and innovate. High job satisfaction reflects a supportive work environment that allows teachers to be creative and experimental. Teachers feel comfortable sharing new ideas, collaborating with fellow teachers, and developing innovative teaching methods, enhancing their creativity. High job satisfaction also can boost teachers' self-confidence in facing challenges and exploring new approaches to teaching. Teachers who are content with their work are more likely to take risks and courageously attempt

innovative methods. It emphasizes the importance of creating a work environment that promotes teacher job satisfaction, as it can stimulate creativity in bringing innovation and improvement to the learning process.

Transformational Leadership on Creativity Through Job Satisfaction

The estimated value of the coefficient output from the Sobel test for this variable had a two-tailed probability value of 0.041, less than 0.05. Therefore, a significant influence of transformational leadership on creativity through job satisfaction was discovered. Job satisfaction succeeds in fully mediated transformational leadership on creativity. Effective transformational leadership creates a motivating work environment and provides recognition to teachers, thereby enhancing their job satisfaction. Teachers who are satisfied with their job are more likely to be motivated and actively engaged in the learning process. Their confidence and self-belief increase, leads them to take risks and try innovative approaches. In this context, teacher creativity is enhanced, and they tend to generate creative ideas in teaching and instructional methods. In an interdependent cycle, transformational leadership increases teacher job satisfaction, stimulating their creativity in generating new ideas and innovation in teaching. Therefore, transformational leadership influences creativity through its positive impact on job satisfaction.

CONCLUSION

Based on the research results and analysis, the following conclusion can be drawn:

Transformational leadership did not directly influence creativity. The research findings indicated no significant direct impact of transformational leadership on creativity. Transformational leadership alone may not directly stimulate or enhance individual creativity among teachers.

Transformational leadership positively influenced job satisfaction. The research demonstrated that transformational leadership significantly positively affected job satisfaction. When teachers perceive their leaders as inspiring, supportive, and empowering, it contributes to higher levels of job satisfaction.

Job satisfaction positively influenced creativity. The findings revealed a positive relationship between job satisfaction and creativity. Teachers who experience higher job satisfaction are more likely to be motivated, engaged, and fulfilled in their work, which fosters a conducive environment for generating creative ideas and innovative practices.

Transformational leadership indirectly influenced creativity through job satisfaction. While there may not be a direct impact of transformational leadership on creativity, the research reveals that Job satisfaction succeeds in fully mediating the influence of transformational leadership on creativity. When teachers feel satisfied with their jobs due to transformational leadership practices, it creates a favorable climate for creativity to flourish.

Suggestion and Limitation

This study only analyzed three variables: transformational leadership, job satisfaction, and creativity. Also, the results indicated that the independent variable did not influence the dependent variable.

It is recommended for future researchers to consider adding another independent variable to determine which variables can influence creativity.

REFERENCES

- Al-Ghazali, M. B., Shah, A. H. S., Gelaidan, H. M., & Amjad, R. (2022). Green Transformational Leadership and Green Creativity? The Mediating Role of Green Thinking and Green Organizational Identity in SMEs. *Frontiers in Psychology, 13*, 1–12. <https://doi.org/10.3389/fpsyg.2022.977998>
- Andriani. (2017). *Pengaruh kompetensi, budaya organisasi dan kepuasan kerja terhadap kreativitas kerja pegawai inspektorat kabupaten kubu raya*. *Jurnal Manajemen Bisnis Universitas Tanjungpura, 5*(4). <https://doi.org/10.26418/ejme.v5i4.21011>
- Anggarwati, A., & Eliyana, A. (2015). The Influence of Creative Self-Efficacy towards Creativity with Job Satisfaction as Intervening Variable at PT. Smile Island Surabaya. *International Journal in Economics and Business Administration, III* (1), 90–99. <https://doi.org/10.35808/ijeba/65>
- Ayranci, E., & Ayranci, A. E. (2017). Relationships among perceived transformational leadership, workers' creativity, job satisfaction, and organizational commitment: An investigation of Turkish banks. *International Journal of Academic Research in Business and Social Sciences, 7*(4), 491–517. <https://doi.org/10.6007/IJARBS/v7-i4/2823>
- Bass, B. M. (1999). Two decades of Research and Development in Transformational Leadership. *European Journal of Work and Organizational Psychology, 8*(1), 9–32. <https://doi.org/10.1080/135943299398410>
- Borodina, T., Sibgatullina, A., & Gizatullina, A. (2019). Developing Creative Thinking in Future Teachers as a Topical Issue of Higher Education. *Journal of Social Studies Education Research, 10*(4), 226–245. Retrieved from <https://www.jsse.org/index.php/jsse>
- Burhanudin, H., Retnowati, R., & Laihah, H. (2022). *Kreativitas guru ditinjau dari kepemimpinan transformasional kepala sekolah dan komunikasi interpersonal*. *Jurnal Manajemen Pendidikan, 10*(1), 030–036. <https://doi.org/10.33751/jmp.v10i1.5062>
- Diansyah. (2018). *Pengaruh kepemimpinan transformasional dan kompensasi terhadap kepuasan kerja melalui komitmen organisasi*. *Media Ekonomi Dan Manajemen, 33*(1). <http://dx.doi.org/10.24856/mem.v33i1.624>
- Fareed, M. Z., Su, Q., Almutairi, M., Munir, K., & Fareed, M. M. S. (2022). Transformational leadership and project success: The mediating role of trust and job satisfaction. *Frontiers in Psychology, 13*. <https://doi.org/10.3389/fpsyg.2022.954052>
- Haryadi, R. N., Sunarsi, D., Erlangga, H., Nurjaya, N., & Hamsinah, H. (2022). *Pengaruh komunikasi dan motivasi terhadap kepuasan kerja karyawan pt timur jaya prestasi*

- cileungsi. *JENIUS (Jurnal Ilmiah Manajemen Sumber Daya Manusia)*, 5(3). <https://doi.org/10.32493/JJSDM.v5i3.20399>
- Hobri, Ummah, I. K., Yuliati, N., & Dafik. (2020). The Effect of Jumping Task Based on Creative Problem Solving on Students' Problem-Solving Ability. *International Journal of Instruction*, 13(1), 387–406. <https://doi.org/10.29333/iji.2020.13126a>
- Jaiswal, N. K., & Dhar, R. L. (2016). Fostering Employee Creativity through Transformational Leadership: Moderating Role of Creative Self-Efficacy. *Creativity Research Journal*, 28(3), 367–371. <https://doi.org/10.1080/10400419.2016.1195631>
- Jufrizen. (2017). *Efek moderasi etika kerja pada pengaruh kepemimpinan transformasional dan budaya organisasi terhadap kinerja karyawan*. *Jurnal Ekonomi Manajemen & Bisnis*, 18(2), 145–158. <https://doi.org/10.29103/e-mabis.v18i2.180>
- Khalid, M., Saad, S., Abdul Hamid, S. R., Ridhuan Abdullah, M., Ibrahim, H., & Shahrill, M. (2020). Enhancing Creativity and Problem-Solving Skills Through Creative Problem Solving in Teaching Mathematics. *Creativity Studies*, 13(2), 270–291. <https://doi.org/10.3846/cs.2020.11027>
- Kim, J.-G., & Lee, S.-Y. (2011). Effects of transformational and transactional leadership on employees' creative behaviour: mediating effects of work motivation and job satisfaction. *Asian Journal of Technology Innovation*, 19(2), 233–247. <https://doi.org/10.1080/19761597.2011.632590>
- Minh-Duc, L., & Huu-Lam, N. (2019). Transformational leadership, customer citizenship behavior, employee intrinsic motivation, and employee creativity. *Journal of Asian Business and Economic Studies*, 26(2), 286–300. <https://doi.org/10.1108/jabes-10-2018-0070>
- Oktavia, Y. (2014). *Usaha kepala sekolah dalam meningkatkan kreativitas guru dalam pembelajaran di sekolah dasar*. *Jurnal Bahana Manajemen Pendidikan*, 2(1), 808–815. <https://doi.org/10.24036/bmp.v2i1.3828>
- Palguna, I. A. G. I., & Supartha, W. G. (2016). *Kepemimpinan transformasional, work family conflict dan komitmen organisasional terhadap kepuasan kerja karyawan*. *Jurnal Manajemen UNUD*, 5(1), 31–58. Retrieved from <https://ojs.unud.ac.id/index.php/manajemen/article/view/19763>
- Palupi, M. (2020). Efforts to Improve Employee Creativity Through Transformational Leadership. *Jurnal Manajemen Bisnis*, 11(2). <https://doi.org/10.18196/mb.112100>
- Palupi, M., & Tjahjono, K. H. (2021). *Apakah keadilan formal penilaian kinerja menjadi determinan kepuasan kerja dan komitmen continuance? MIX: Jurnal Ilmiah Manajemen*, 11(1), 121–135. <http://dx.doi.org/10.22441/mix.2021.v11i1.009>
- Pardamean, T. (2009). *Profesionalitas Guru Perlu Daya Kreativitas*. Alfabeta.
- Pramana, M. (2017). *Pengaruh budaya organisasi, kompensasi terhadap kepuasan serta dampaknya terhadap kreativitas kerja guru-guru di lingkungan yayasan marsudirini perwakilan jalan pemuda*. *Jurnal Bingkai Ekonomi*, 2. Retrieved from <https://itbsemarang.ac.id/sijies/index.php/jbe33/article/view/38>

- Puji Astuti, T., Sitawati, R., & Dharmaputra Semarang, S. (2019). *Pengaruh kreativitas dan perilaku inovatif terhadap kinerja karyawan dengan kepuasan kerja sebagai variabel mediasi (studi pada hotel pandanaran semarang)*. *Jurnal Ekonomi Manajemen Dan Akuntansi*. Retrieved from <http://stiedharmaputra-smg.ac.id>
- Ripki, A., Murni, S., & Wahyudi, M. (2020). *Creative thinking of vocational high school teachers: effects of transformational leadership and job satisfaction*. *International e-Journal of Educational Studies*, 4(7), 93–105. <https://doi.org/10.31458/iejes.608021>
- Robbins, S. P., & J. T. (2012). *Essentials of organizational behavior*. (11th ed.). Pearson Education Inc.
- Rumondang Malau, A., & Sianipar, G. (2019). *Dampak gaya kepemimpinan transformasional, kepemimpinan transaksional dan orientasi pembelajaran terhadap kreativitas mahasiswa dengan variabel pemediasi creative self-efficacy*. *Anne Rumondang Malau*, 1(2), 186–200. <https://doi.org/10.52160/ejmm.v3i2.200>
- Salau, O., Oludayo, O., Falola, H., Olokundun, M., Ibidunni, S., & Atolagbe, T. (2018). Integrated datasets on transformational leadership attributes and employee engagement: The moderating role of job satisfaction in the Fast-Moving Consumer Goods (FMCG) industry. *Data in Brief*, 19, 2329–2335. <https://doi.org/10.1016/j.dib.2018.06.032>
- Sofyan, F. J., & Rianty Mardina. (2023). *Karakteristik manajemen dan kepemimpinan transformasional sebagai penentu kreativitas karyawan yang dimediasi oleh kepuasan kerja*. *Jurnal Maksipreneur (Manajemen, Koperasi, Dan Entrepreneurship)*, 12(2), 448–470. <https://doi.org/10.30588/jmp.v12i2.1186>
- Spanjol, J., Yin, W., Tam, L., & Tam, V. (2015). Employer-employee congruence in environmental values: an exploration of effects on job satisfaction and creativity effects on job satisfaction and creativity. *Journal of Business Ethics*, 130(1), 117–130. <https://ro.uow.edu.au/buspapers>
- Taruna, I. (2019) Factors affecting turnover intention, *International Journal of Innovation, Creativity, and Change*, 7(9), 251-260
- Spector, P. E. (1997). *Job satisfaction: Application, assessment, cause, consequences*. Sage Publication.
- Sudjijana, M. Y. S. (2020). *Pengaruh kepemimpinan transformasional, iklim inovasi, efikasi diri terhadap kreativitas karyawan pada industri pembuatan gerabah di desa kasongan, kabupaten bantul*. *Jurnal Ekobis Dewantara*, 2(3). https://doi.org/10.26460/ed_en.v2i3.1600
- Sunaryo, W., Yusnita, N., Herfina, H., Wulandari, D., & Suhendra, S. (2023). The Effects of Digital Transformational Leadership, Work Environment and Motivation on Reinforcing Job Satisfaction: Evidence from Vocational Schools. *International Journal of Data and Network Science*, 7(2), 883–890. <https://doi.org/10.5267/j.ijdns.2022.12.023>
- Talajan, G. (2012). *Menumbuhkan Kreativitas dan Prestasi Guru*. Laksbang Pressindo.

- Tamsah, H., Ilyas, J. B., & Yusriadi, Y. (2021). Create teaching creativity through training management, effectiveness training, and teacher quality in the covid-19 pandemic. *Journal of Ethnic and Cultural Studies*, 8(4), 18–35. <https://doi.org/10.29333/ejecs/800>
- Tjahjono, H. K. (2004). *Budaya Organisasional dan balanced scorecard: Dimensi Teori dan Praktik*. UPFE, UMY.
- Tjahjono, H. K. (2015). *Manajemen Sumberdaya Manusia*. VSM MM UMY.
- Tjahjono, H. K., Prasetyo, F., & Palupi, M. (2018). *Kepemimpinan transformasional pada organizational citizenship behavior dan komitmen afektif*. *Jurnal Manajemen Dan Pemasaran Jasa*, 11(2). <http://dx.doi.org/10.25105/jmpj.v11i2.2771>
- Tjahjono, H.K., Agus T.B. & Palupi, M. (2021). *Aplikasi SEM dalam Studi Perilaku Organisasional*. UPP STIM YKPN.
- Wijayanti, D., & Supartha, G. (2019). *Pengaruh kepemimpinan transformasional terhadap kreativitas karyawan dimediasi efikasi diri kreatif pada pt. Aura bali craft*. *Jurnal Manajemen UNUD*, 8(3), 1230–1254. <https://doi.org/10.24843/EJMUNUD.2019.v08.i03.p03>
- Zhou, J., George, J. M., & Jones, J. H. (2001). When Job Dissatisfaction Leads To Creativity: Encouraging The Expression Of Voice. *Academy of Management Journal*.