

Flower Pollination Algorithm to Tune PID Controller of TCP/AQM Wireless Networks

Suad Ali Eissa ¹, Salam Waley Shneen ^{2*}, Ekbal Hussein Ali ³

^{1,3} Department of Electromechanical Engineering, University of Technology, Iraq

² Nanotechnology and advanced material research Center, University of Technology, Iraq

Email: ¹ suad.a.eissa@uotechnology.edu.iq, ² salam.w.shneen @uotechnology.edu.iq, ³ ekbal.h.ali@uotechnology.edu.iq

*Corresponding Author

Abstract— The current study aims to conduct a simulation that is useful in developing an appropriate design that addresses the problem of congestion in the Internet network through controlling the queue of the router. The simulation is conducted through the proposed model for simulation with different control systems that help in raising the quality of performance such as traditional Proportional Integral Derivative (PID) and advanced optimal by Flower Pollination Algorithm (FPA). It depends for Transmission Control Protocol/ Active Queue Management (TCP/AQM) simulation model for a linear system and another non-linear system. To adjust the network work and raise the level of performance, different control systems were chosen, taking into account all the things that appear through conducting experiments and for different purposes. One of the most important things that must be taken into consideration is the system disturbances as a result of the volume and values of the data, causing congestion. It was shown through the results of the experiments that were conducted considering the cases of the linear and nonlinear system to pass data traffic in the network and by adopting the different techniques of the control units, the preference of optimization systems over the traditional ones, as well as the preference of the traditional over without control in close loop, is the improvement of the performance of linear systems compared to the open and closed system without control. The simulation results showed that very clear the superiority of the optimization by FPA-PID controller over the conventional system (PID), as well as very clear the superiority of the traditional system (PID) over closed system without control and open loop system.

Keywords— Flower Pollination Algorithm; Wireless Networks; Proportional Integral Derivative; Active Queue Management; Transmission Control Protocol

I. INTRODUCTION

The Internet is a network for transferring data between users of different disciplines as quickly as possible [1]-[3]. For every system, including the web-based system, there are problems that cause poor performance, including data loss or delays [4]-[6]. The reason for this is the large number of data as a result of the large number of users, which causes congestion resulting from the waiting list [7]-[9]. Multiple transmitting sources make the network congested, in addition to multiple receiving sources, speed and time are among the factors involved in evaluating the size or smallness of the problem [10]-[12]. Various methodologies have been developed to deal with all the problems and to control congestion caused by overload on the network [13]-[15]. The problem can be addressed before it appears to avoid

crowding, according to appropriate procedures by adopting control techniques [16]-[20].

Control systems are used with control protocols, queue management systems, and auxiliary routers [21]-[23]. Feedback control techniques can be applied publicly and easily to the problem of crowding control [24]-[26]. Performance optimization is achieved through efficient queue control and time required reduction through quality routing to reduce loss within closed-loop scope with feedback and conventional, expert or controller modules smart. The time factor has the greatest effect in changing the state of TCP performance and reaching acceptable performance based on AQM using a suitable algorithm for this improvement as a result of changing the state of the load, traffic or traffic process. Such as PID, PI, PD, expert such as fuzzy logic, neural networks, advanced optimization such as genetic algorithm, and others [27]-[29].

It is proposed to test three different queue management methods to address the congestion problem in the Internet. A model is designed to simulate a TCP/AQM network, test it, and verify the performance improvement by adopting the proposed control systems with disorder states, linear and nonlinear systems. The optimization process is done according to the principle of prediction and expectation. And evaluation to identify the models under test to reach the best quality model through fast response, reduce waiting time, and ensure data access without loss. Through the simulation results, it is possible to improve the performance by adopting the closed-loop system better than the open-loop. It has also been shown from the simulation results for a second case of a closed-loop system with a conventional control unit that is better than the case without a control unit. In the linear system, the traditional control unit proved to be superior to the closed-loop condition without a controller, while in the non-linear system, the results showed that the traditional system is not at the required level, and the advanced optimization is the best traditional control system to raise the level of performance.

II. PID CONTROLLER FOR AN TCP/AQM USING FPA

Flower Pollination Algorithm, the flower pollination algorithm (FPA) is one of the algorithms that have been verified to be used to adjust the parameters of a conventional PID controller. An important application that can be used is the conventional microcontroller parameterized by high precision microcontroller technology such as the flower



pollination algorithm (FPA). When using any optimization technique, performance indicators are adopted that can be tested to find out the best response by comparing them. The comparison depends on the response speed, rise time, and the above and below the level required to complete the process of analyzing the response for different system cases. Among the indicators that are used are IAE, ITAE, and ISE, in addition to the types of others. Different system cases are tested open circuit, closed circuit, without control, with conventional control unit and other advanced optimization FPA [30-33]. Flowchart of optimization FPA shown in Fig. 1.

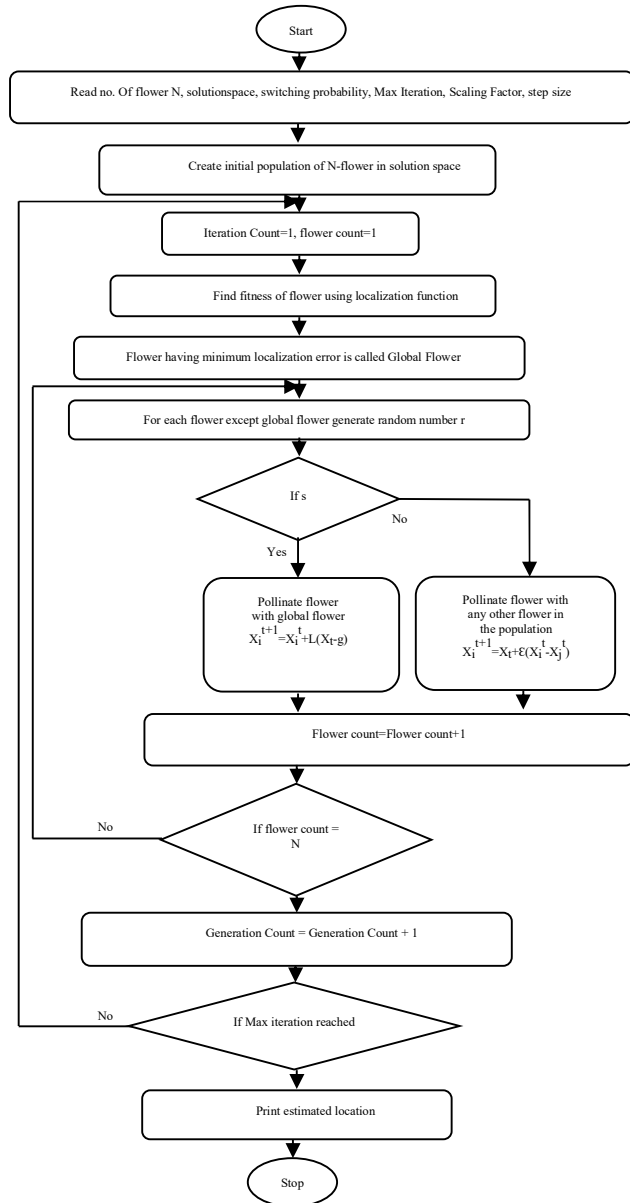

Fig. 1. Flowchart of optimization FPA [34-37]

Algorithm of Flower Pollination, the first stage aims to determine the highest and lowest value that can be among the best expected values from previous experiences $f(x), x = (x_1, x_2, \dots, x_d)$. After determining the highest and lowest value that enables us to achieve the desired goal, we work with the step. The second is to choose a group of n flowers that undergo pollination within the rules of the proposed

algorithm. Using random solutions to search for the best among the proposed group g . Find the potential permutation and motion for each $i = 1$ flower of a group of n flowers, plotting the directions of motion within a Levy. Work is being done to find random solutions subject to evaluation to obtain the best solutions, including g [38-43].

The PFA rules include the first rule that biological pollination is considered to be a global pollination process, which can be subject to the movement of the pollinator within the flight of a Levy. The second rule is that the second type of vaccination, which is non-biological or self-fertilization, can be considered as local, not global. The second rule is that the second type of vaccination, which is non-biological or self-fertilization, can be considered as local, not global. There is also a third rule, the possibility of reproduction on the basis of considerations in the regularity of flowers, and there is a possibility of reproduction by the similarity of the two pollinating flowers participating in that process. Finally, or the last and fourth rule, the possibility of self- or mutual pollination, on the assumption that each flower works on a solution and has the possibility of improvement in the procedures for the reproduction of offspring. Also, the possibility depends on conversions between global and local vaccination and the so-called mass vaccination and includes two bases at the same time [44-48].

The global pollination and local pollination as show in (1) and (2).

$$x_i^{t+1} = x_i^t + \gamma L(\lambda)(g - x_i^t) \tag{1}$$

where X_i t is pollen, i is iteration, g is best iterative, $L(\lambda)$ is based on Levy flight, γ is scale factor.

$$x_i^{t+1} = x_i^t + \epsilon(x_j^t - x_k^t) \tag{2}$$

Note: Randomly choose j and k among all the solutions.

Work is underway to reach an appropriate design by obtaining the best values for the parameters of the traditional PID controller based on FPA technology and as an application we adopt the Internet and the TCP/AQM system to solve the congestion problem. This technique works to improve performance according to an algorithm inspired by the environment that matches two types of pollination of the two plants, which are flowers with self-pollination and another mutual, and to obtain optimal reproduction [49-55]. Optimal Design of PID controller for an TCP/AQM using flower pollination algorithm shown in Fig. 2.

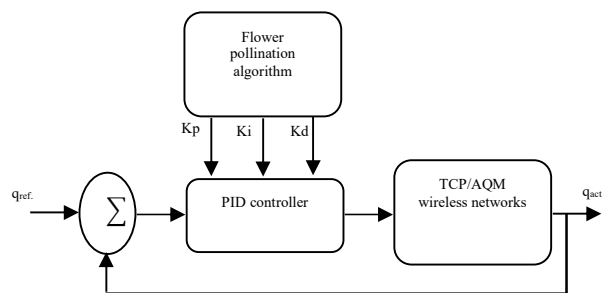

Fig. 2. Optimal Design of PID Controller for an TCP/AQM Using Flower Pollination Algorithm

Systems generally operate in one of two modes, either an open-loop system or a closed-loop system. The open-loop system is a system that is not sensitive to the changes that occur during its work, such as the operation of the water heater without taking into account the temperature or coldness of the air. Rather, time periods are specified for operation. While in the other system, which is a closed-loop, there is a sensor that senses the temperature or coldness of the air simultaneously for every moment [56-58].

A closed-loop system automatically regulates the system to a state that is intended to be stable with feedback to maintain a stable system such as a home thermostat. In modern and advanced systems, controllers have been added to the systems to improve their performance, including traditional, expert, smart, and advanced optimization. Control systems added to closed-loop systems adjust the system as a result of any transient condition that may harm the system, such as controlling the speed of the air conditioner, as regulating those helps protect the compressor from damage [59-62].

The system's inputs and outputs are linked to mathematical relations, and as a result of changes that may occur in the system, the system's outputs change accordingly. And then an error is generated at which the system needs a process of adjusting and restoring the state to normal, and this is the function of the controller. In order to reach the best operation of the system, it requires studying different cases and methods of improvement, comparing them in terms of response accuracy and speed. The system's stability and instability need relative treatment as required and decided. To verify the system's response, it is represented by a simulation model within specifications that simulate systems in real time to develop an appropriate design [63-65].

The simulation is conducted according to the TCP model that organizes the queue for Internet traffic and addresses the congestion problem. Over time, the rate of data flow changes, so those changes must be taken into account and addressed. An open-loop model is built to observe the performance of the system at that state and identify its disadvantages. Likewise, the closed-loop system, and to note the difference in performance to improve performance, a third model is developed with a traditional controller. Finally, it is desired to reach parameters that give a high-precision and efficient response through the performance of the queue, which requires organizing the parameters of the traditional controller into values that give better results, using the advanced optimization. The current simulation provided traffic and the creation of its model with the crash protocol by TCP and monitoring its results and loss rates for each model of an open and closed loop and a conventional and optimal controller. Different interpretations can be developed for each case when analyzing its different results, including the rate of rise time, stability time, and the rate of over and under. The open one does not respond as well as the closed one, which results in network problems. Network problems are bypassed through the verification process using traditional and advanced server optimization control units [66-68].

III. MODELING AND SIMULATION OF SYSTEM

Mathematical Models of TCP/AQM, the required simulation model can be built according to the network structure represented by the router as a linear or nonlinear model, as through the description, the model can be represented according to differential equations. There are two section, first modeling system and second simulation system. The factors suppose of the network of TCP/AQM system include, $Tp=0.2$ s., $C = 300$ packets/s, $R0=0.533$, $N=50$ TCP sessions and $W0= 3.2$ packets.

A. Modeling System

In this section there are two parts, linear system, nonlinear system. The proposed simulation model includes the components of the system and the function of each component and by adopting its specifications that suit the application as shown in the mathematical representation of the model and the figures below show the structure of the system according to the proposed model. In Fig. 3 show a system without controller, in Fig. 4 a system with controller, in Fig. 5 a controller of a TCP network and Fig. 6. TCP/AQM network.

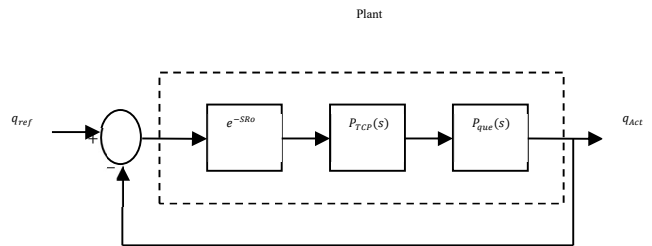

Fig. 3. Close loop system of an AQM network without controller

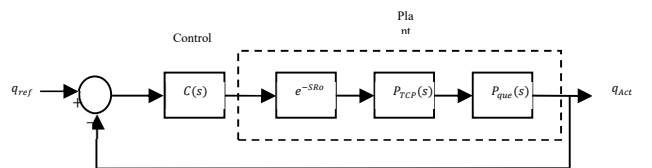

Fig. 4. Close loop system of an AQM network with controller

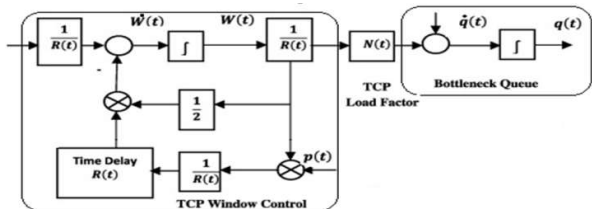

Fig. 5. A controller of a TCP network

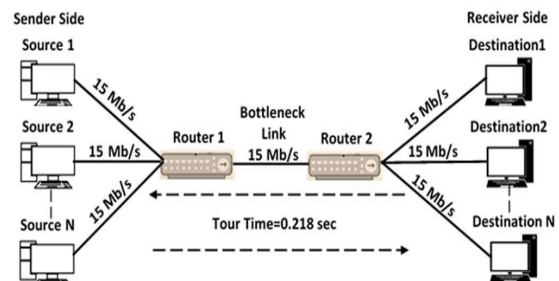

Fig. 6. TCP/AQM network

These systems have mathematical modeling by using many parameters of system that show in (3)-(7) [69-71].

$$\dot{w}(t) = \frac{1}{\frac{q(t)}{c} + T_p} - \frac{w(t)}{2} \frac{w(t - R(t))}{\frac{q(t - R(t))}{c} + T_p} p(t - R(t)) \quad (3)$$

$$\dot{q}(t) = \begin{cases} -C + \frac{N(t)}{\frac{q(t)}{c} + T_p} w(t) & \text{if } q(t) > 0 \\ \max \left\{ 0, -C + \frac{N(t)}{\frac{q(t)}{c} + T_p} w(t) \right\} & \text{if } q(t) = 0 \end{cases} \quad (4)$$

$$F(s) = \frac{q(s)}{p(s)} = \frac{\frac{c^2}{2N} e^{-sR}}{(s + \frac{2N}{R^2 C})(s + \frac{1}{R})} \quad (5)$$

$$\text{sat}(p(t - R(t))) = \begin{cases} 1, & p(t - R(t)) \geq 1 \\ p(t - R(t)), & 0 \leq p(t - R(t)) < 1 \\ 0, & p(t - R(t)) < 0 \end{cases} \quad (6)$$

$$T.F = \frac{900}{s^2 + 2.314s + 1.338} \quad (7)$$

where q is queue length, w is TCP window size, T_p is promulgation delay, N is load factor, R is transfer rate for TCP (seconds) is $(q/C) + T_p$, C is capacity of the link, and p is packet sign probability.

B. Simulation System

In this section there are four part , first modeling and simulation of system for open loop TCP/AQM wireless networks that show in Fig. 7. Second modeling and simulation system for closed loop without controller of TCP/AQM wireless networks that show in Fig. 8. Third modeling and simulation system for closed loop with PID controller of TCP/AQM wireless networks that show in Fig. 9. Fourth modeling and simulation system for closed loop with Flower Pollination Algorithm of TCP/AQM wireless networks that show in Fig. 10.

As mentioned above, to represent the network used to transfer data between users in a simulation model to address those problems that lead to poor performance due to the large number of data as a result of the large number of users. A simulation was conducted by adopting models for the cases that were proposed and represented by the Fig. 7-10. Fig. 7 represents the first test case, which represents the case of an open-loop system, that is, a system with no feedback. The results of this case can be obtained and discussed later in the next paragraph of the current research. The other system case when there is feedback for the closed-loop system, which differs from the first case, and it can be verified The difference during the simulation and what the results of the two cases show. In order to calculate the performance, a third case was proposed by adding different control systems. The current simulation included two types of control systems to verify the possibility of using them in improving performance and to compare them to find out what is best for dealing with data loss or delay, which appears through simulation using models.

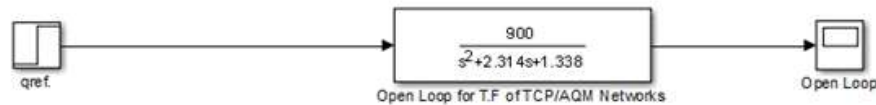

Fig. 7. Open loop TCP/AQM wireless networks

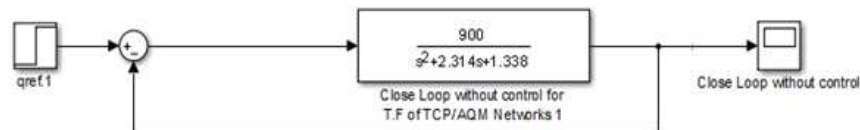

Fig. 8. Closed loop without controller of TCP/AQM wireless networks

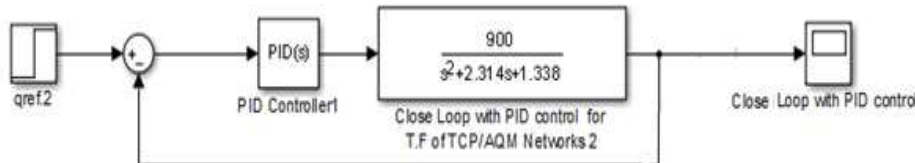

Fig. 9. Closed loop with PID controller of TCP/AQM wireless networks

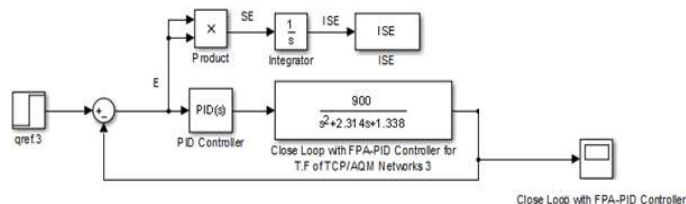

Fig. 10. Closed loop with Flower Pollination Algorithm of TCP/AQM wireless networks

IV. SIMULATION RESULTS

In this section, the simulation model is used using Fig. 9 to conduct the proposed tests to obtain results that achieve the procedures required to develop the proposed system to reach the design of a high-performance model. Fig. 12-18 show the simulation results, which can be analyzed each according to its condition, including an open loop with high performance It can be represented by Fig. 13 and another, the system state of a closed loop without a control unit, by Fig. 14. Also, Fig. 15 and Fig. 16 show the two cases of using the traditional with PID controller and advanced control unit with FPA- PID Controller. Which of the divorces was faster, as well as the level and rate of the lower and upper bypass of the required peak value. There is also the time of stability and speed of response.

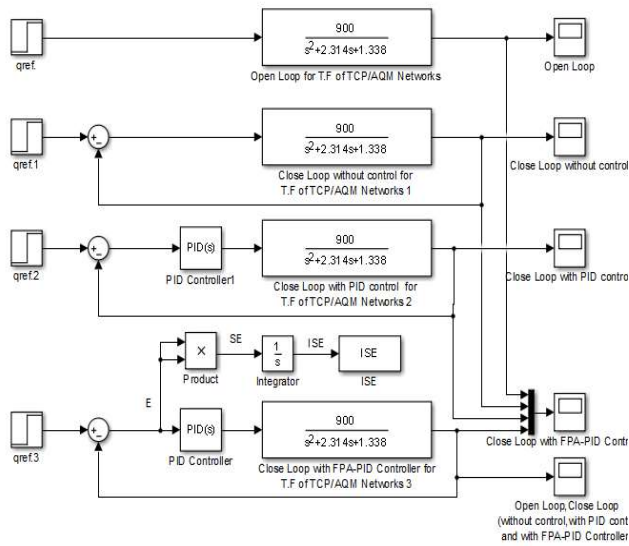

Fig. 11. Simulation model for closed loop with FPA, PID Controller, without controller and open loop of TCP/AQM wireless networks

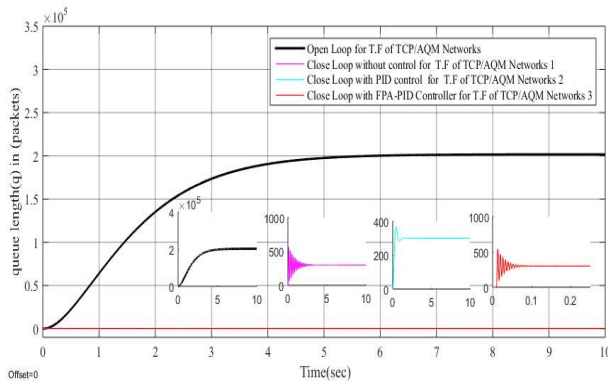

Fig. 12. Simulation result for closed loop with FPA- PID Controller, PID Controller, without controller and open loop of TCP/AQM wireless networks

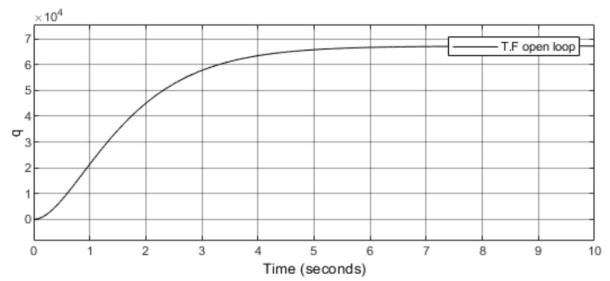

Fig. 13. Simulation result for open loop of TCP/AQM wireless networks

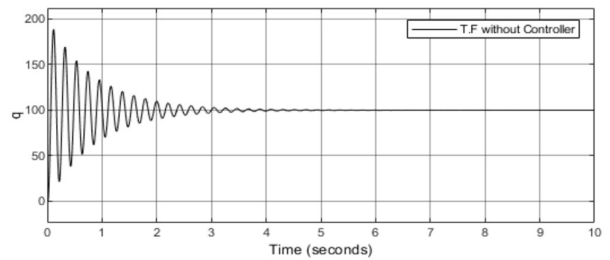

Fig. 14. Simulation result for closed loop without controller of TCP/AQM wireless networks

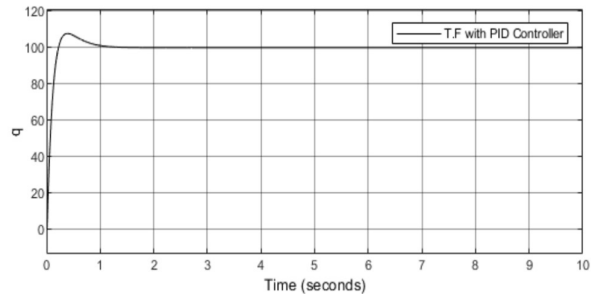

Fig. 15. Simulation result for closed loop with PID controller of TCP/AQM wireless networks

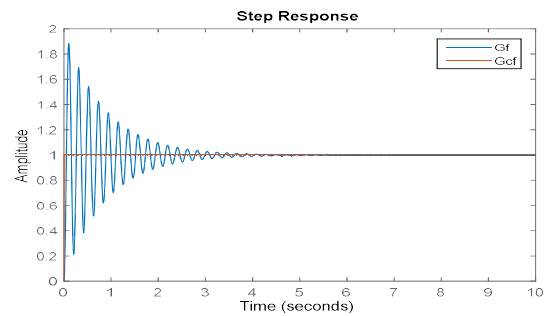

Fig. 16. Simulation result for closed loop with FPA- PID Controller of TCP/AQM wireless networks

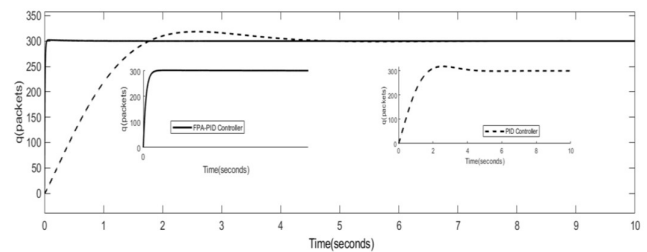

Fig. 17. Simulation result for FPA- PID and PID Controller of TCP/AQM wireless networks

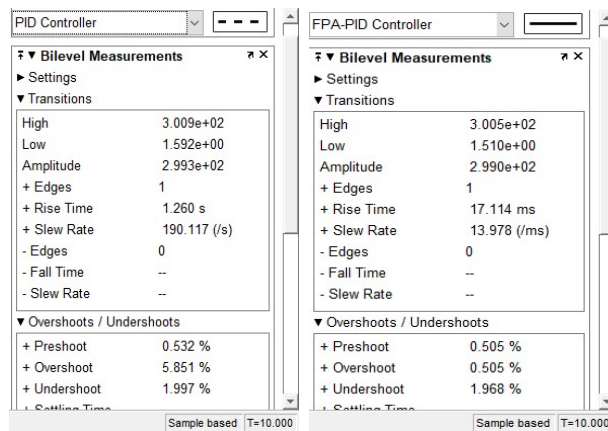

Fig. 18. Comparative between FPA- PID and PID Controller for TCP / AQM wireless networks

In Fig. 12-18. Simulation results aim to develop and improve different methodologies that enable dealing with all problems of the Internet and controlling congestion resulting from excessive loads on that network. To address the problem of congestion in the Internet by adopting queue management, three different methods are proposed to be tested. To simulate a TCP/AQM network with disorder states, linear and nonlinear systems. In order to reach the best model, a performance improvement model is designed and tested. The optimization process is carried out according to the adoption of control systems through rapid response, reducing waiting time, and ensuring access to data without loss.

Simulation results show that the performance can be improved by adopting the closed-loop system better than the open-loop. Simulation results for another case showed that the closed loop with the use of traditional control systems is better than the previous one that does not contain a control unit. In the linear system, the traditional control unit proved to be superior to the closed-loop condition without a controller, while in the non-linear system, the results showed that the traditional system is not at the required level, and advanced optimization is the best traditional control system to raise the level of performance.

V. CONCLUSION

The simulation needs to prepare a model, including the linear and the non-linear one, as a result of a change that takes place with time. The Internet is a network that needs to be used by many users, and their number changes over time. Dealing with cases requires a control mechanism because there are situations that create problems. Work is needed to find appropriate solutions. Delay as a result of congestion is a problem that is dealt with to reduce damage or get rid of it. TCP/AQM wireless networks is one of the approved protocols Studies have shown that they can be used to solve the problem of congestion by organizing the queue. Control systems based on the prediction process as a result of previous experiences help in designing an appropriate model. Performance improvement using traditional methods with linear systems compared to without a control unit. Results have proven to improve performance as well. The use of advanced systems (Flower Pollination Algorithm) with linear and nonlinear systems gives better results compared to traditional control systems (PID Controller). Simulations were conducted for four cases, including an open system,

another closed loop without control, another with traditional control systems, and finally the optimal advance by Flower Pollination Algorithm.

REFERENCES

- [1] A. Afanasyev, N. Tilley, P. Reiher, and L. Kleinrock, "Host-to-Host Congestion Control for TCP," in *IEEE Communications Surveys & Tutorials*, vol. 12, no. 3, pp. 304-342, 2010.
- [2] R. Munadi, D. D. Sanjoyo, D. Perdana, and F. Adjic, "Performance analysis of tunnel broker through open virtual private network," *TELKOMNIKA (Telecommunication Computing Electronics and Control)*, vol. 17, no. 3, pp. 1185-1192, 2019.
- [3] Y. Liu, X. Liu, Y. Jing, Z. Zhang, and X. Chen, "Congestion tracking control for uncertain TCP/AQM network based on integral backstepping," *ISA transactions*, vol. 89, pp. 131-138, 2019.
- [4] W. Kurniawan, M. H. H. Ichsan, and S. R. Akbar, "UDP pervasive protocol implementation for smart home environment on MyRIO using LabVIEW," *International Journal of Electrical and Computer Engineering (IJECE)*, vol. 8, no. 1, pp. 113-123, 2018.
- [5] A. Eryilmaz and R. Srikant, "Fair Resource Allocation in Wireless Networks Using Queue-Length-Based Scheduling and Congestion Control," in *IEEE/ACM Transactions on Networking*, vol. 15, no. 6, pp. 1333-1344, 2007.
- [6] G. A. Azim, M. H. Jaber, M. Q. Sulttan, and S. W. Shneen, "Simulation Model of Enhancing Performance of TCP/AQM Networks by Using Matlab," *Journal of Engineering & Technological Sciences*, vol. 54, no. 4, 2022.
- [7] Y. Gao, G. He, and J. C. Hou, "On exploiting traffic predictability in active queue management," *Proceedings Twenty-First Annual Joint Conference of the IEEE Computer and Communications Societies*, vol. 3, pp. 1630-1639, 2002.
- [8] N. Nigar and M. A. Azim, "Fairness Comparison of TCP Variants over Proactive and Reactive Routing Protocol in MANET," *International Journal of Electrical & Computer Engineering (2088-8708)*, vol. 8, no. 4, 2199-2206, 2018.
- [9] Y. Gong, D. Rossi, C. Testa, S. Valenti, and M. D. Täht, "Fighting the bufferbloat: On the coexistence of AQM and low priority congestion control," *2013 IEEE Conference on Computer Communications Workshops (INFOCOM WKSHPs)*, pp. 411-416, 2013.
- [10] M. I. B. Samsuddin, M. Y. Darus, S. J. Elias, A. H. M. Taib, N. Awang, and R. Din, "The evaluation of AdBlock technique implementation for enterprise network environment," *Indonesian Journal of Electrical Engineering and Computer Science*, vol. 13, no. 3, pp. 1102-1109, 2019.
- [11] S. Patel, P. Gupta, and G. Singh, "Performance measure of Drop tail and RED algorithm," *2010 2nd International Conference on Electronic Computer Technology*, pp. 35-38, 2010.
- [12] S. W. Shneen, M. Q. Sulttan, and M. K. Oudah, "Design and implementation of a stability control system for TCP/AQM network," *Indonesian Journal of Electrical Engineering and Computer Science*, vol. 22, no. 1, pp. 129-136, 2021.
- [13] M. Sagfors, R. Ludwig, M. Meyer, and J. Peisa, "Queue management for TCP traffic over 3G links," *2003 IEEE Wireless Communications and Networking, 2003. WCNC 2003.*, vol. 3, pp. 1663-1668, 2003.
- [14] M. C. Weigle, K. Jeffay, and F. D. Smith, "Delay-based early congestion detection and adaptation in TCP: impact on web performance," *Computer Communications*, vol. 28, no. 8, pp. 837-850, 2005.
- [15] O. Kennedy, E. Chukwu, O. Shobayo, E. N. Osaghae, I. Okokpujie, and M. Odusami, "Comparative analysis of the performance of various active queue management techniques to varying wireless network conditions," *International Journal of Electrical and Computer Engineering*, vol. 9, no. 1, pp. 359-368, 2019.
- [16] G. Di Fatta, F. Hoffmann, G. Lo Re, and A. Urso, "A genetic algorithm for the design of a fuzzy controller for active queue management," in *IEEE Transactions on Systems, Man, and Cybernetics, Part C (Applications and Reviews)*, vol. 33, no. 3, pp. 313-324, 2003.
- [17] M. Q. Sulttan, M. H. Jaber, and S. W. Shneen, "Proportional-integral genetic algorithm controller for stability of TCP network," *International Journal of Electrical and Computer Engineering (IJECE)*, vol. 10, no. 6, pp. 6225-6232, 2020.
- [18] H. Hamidian and M. T. Beheshti, "A robust fractional-order PID controller design based on active queue management for TCP

- network," *International Journal of Systems Science*, vol. 49, no. 1, pp. 211-216, 2018.
- [19] S. S. Sabry and N. M. Kaïttan, "Grey wolf optimizer based fuzzy-PI active queue management design for network congestion avoidance," *Indonesian Journal of Electrical Engineering and Computer Science*, vol. 18, no. 1, pp. 199-208, 2020.
- [20] E. H. Ali, E. H. Karam, and H. A. Abbas, "Design and implementation of fuzzy PID controller for single link flexible joint robotic system using FPGA," *International Journal of Computer Applications*, vol. 97, no. 7, pp. 0975-8887, 2014.
- [21] S. W. Shneen, C. Mao, and D. Wang, "Advanced optimal PSO, Fuzzy and PI controller with PMSG and WTGS at 5Hz side of generation and 50Hz Side of Grid," *International Journal of Power Electronics and Drive Systems*, vol. 7, no. 1, p. 173, 2016.
- [22] X. Wang, Y. Wang, H. Zhou, and X. Huai, "PSO-PID: a novel controller for AQM routers," *2006 IFIP International Conference on Wireless and Optical Communications Networks*, pp. 5, 2006.
- [23] S. K. Bisoy and P. K. Pattnaik, "Design of feedback controller for TCP/AQM networks," *Engineering science and technology, an international journal*, vol. 20, no. 1, pp. 116-132, 2017.
- [24] C. V. Hollot, V. Misra, D. Towsley, and W. Gong, "Analysis and design of controllers for AQM routers supporting TCP flows," in *IEEE Transactions on Automatic Control*, vol. 47, no. 6, pp. 945-959, 2002.
- [25] S. W. Shneen, M. Q. Sulttan, and M. H. Jaber, "Variable speed control for 2Ph-HSM in RGS: a comparative simulation study," *International Journal of Electrical and Computer Engineering*, vol. 10, no. 3, p. 2285, 2020.
- [26] H. M. Kadhim and A. A. Oglah, "Congestion avoidance and control in internet router based on fuzzy AQM," *Engineering and Technology Journal*, vol. 39, no. 2A, pp. 233-247, 2021.
- [27] H. A. Abdulmohtsin, "Design and Implementation a Server Receiving Data in Both Forms TCP and UDP Through the Same Port and its Impact on the Network Performance," *Engineering and Technology Journal*, vol. 34, no. 2, pp. 317-327, 2016.
- [28] S. N. Abdullah, B. A. Jumaa, and O. A. Mohamad, "Effect of Using Header Compression Method in TCP/IP Protocol Over HDLC in SCADA System," *Engineering and Technology Journal*, vol. 27, no. 15, pp. 2806-2813, 2009.
- [29] L. H. Abood, B. K. Olewi, and E. H. Ali, "Optimal backstepping controller for controlling DC motor speed," *Bulletin of Electrical Engineering and Informatics*, vol. 11, no. 5, pp. 2564-2572, 2022.
- [30] S. W. Shneen, D. H. Shaker, and F. N. Abdullah, "Simulation model of PID for DC-DC converter by using MATLAB," *International Journal of Electrical and Computer Engineering*, vol. 11, no. 5, pp. 3791-3797, 2021.
- [31] T. H. Harahap *et al.*, "A New Commodity Distribution Approach Based on Asymmetric Traveler Salesman Using Ant Colony Algorithm," *Industrial Engineering & Management Systems*, vol. 21, no. 3, pp. 538-546, 2022.
- [32] J. Dalle, P. Chettham, G. Widjaja, E. Dudukalov, A. H. Iswanto, and E. S. Sergushina, "Route optimization of container ships using differential evolution and gray wolf optimization," *Industrial Engineering & Management Systems*, vol. 20, no. 4, pp. 604-612, 2021.
- [33] E. S. Rahayu, A. Ma'arif, and A. Çakan, "Particle swarm optimization (PSO) tuning of PID control on DC motor," *International Journal of Robotics and Control Systems*, vol. 2, no. 2, pp. 435-447, 2022.
- [34] D. Potnuru, K. A. Mary, and C. S. Babu, "Experimental implementation of Flower Pollination Algorithm for speed controller of a BLDC motor," *Ain Shams Engineering Journal*, vol. 10, no. 2, pp. 287-295, 2019.
- [35] K. Jagatheesan *et al.*, "Application of flower pollination algorithm in load frequency control of multi-area interconnected power system with nonlinearity," *Neural Computing and Applications*, vol. 28, pp. 475-488, 2017.
- [36] M. E. Çimen, Z. B. Garip, and A. F. Boz, "Chaotic flower pollination algorithm based optimal PID controller design for a buck converter," *Analog Integrated Circuits and Signal Processing*, vol. 107, no. 2, pp. 281-298, 2021.
- [37] M. R. Djalal and I. Robandi, "Optimization of PID controller design for DC motor based on flower pollination algorithm," in *The 2015 International Conference on Electrical, Telecommunication and Computer Engineering*, 2015.
- [38] S. Nadweh, O. Khaddam, G. Hayek, B. Atieh, and H. H. Alhelou, "Optimization of P& PI controller parameters for variable speed drive systems using a flower pollination algorithm," *Heliyon*, vol. 6, no. 8, p. e04648, 2020.
- [39] I. Suwarno, A. Ma'arif, N. M. Raharja, T. K. Hariadi, and M. A. Shomad, "Using a combination of PID control and Kalman filter to design of IoT-based telepresence self-balancing robots during COVID-19 pandemic," *Emerging Science Journal*, vol. 4, pp. 241-261, 2020.
- [40] A. Ma'arif and N. R. Setiawan, "Control of DC motor using integral state feedback and comparison with PID: simulation and arduino implementation," *Journal of Robotics and Control (JRC)*, vol. 2, no. 5, pp. 456-461, 2021.
- [41] A. L. Shurajji and S. W. Shneen, "Fuzzy Logic Control and PID Controller for Brushless Permanent Magnetic Direct Current Motor: A Comparative Study," *Journal of Robotics and Control (JRC)*, vol. 3, no. 6, pp. 762-768, 2022.
- [42] N. C. Damasceno and O. G. Filho, "PI controller optimization for a heat exchanger through metaheuristic Bat Algorithm, Particle Swarm Optimization, Flower Pollination Algorithm and Cuckoo Search Algorithm," in *IEEE Latin America Transactions*, vol. 15, no. 9, pp. 1801-1807, 2017.
- [43] K. Jagatheesan, B. Anand, and S. Samanta, "Flower pollination algorithm tuned PID controller for multi-source interconnected multi-area power system," *Applications of Flower Pollination Algorithm and its Variants*, pp. 221-239, 2021.
- [44] D. Lakshmi, A. P. Fathima, and R. Muthu, "A novel flower pollination algorithm to solve load frequency control for a hydro-thermal deregulated power system," *Circuits and Systems*, vol. 7, no. 4, pp. 166-178, 2016.
- [45] I. Hussain, S. Ranjan, D. C. Das, and N. Sinha, "Performance analysis of flower pollination algorithm optimized PID controller for wind-PV-SMES-BESS-diesel autonomous hybrid power system," *International Journal of Renewable Energy Research (IJRER)*, vol. 7, no. 2, pp. 643-651, 2017.
- [46] P. Dash, L. C. Saikia, and N. Sinha, "Flower pollination algorithm optimized PI-PD cascade controller in automatic generation control of a multi-area power system," *International Journal of Electrical Power & Energy Systems*, vol. 82, pp. 19-28, 2016.
- [47] D. Puangdownreong, "Fractional order PID controller design for DC motor speed control system via flower pollination algorithm," *ECTI Transactions on Electrical Engineering, Electronics, and Communications*, vol. 17, no. 1, pp. 14-23, 2019.
- [48] F. D. Murdianto, A. R. Nansur, A. S. L. Hermawan, E. Purwanto, A. Jaya, and M. M. Rifadil, "Modeling and Simulation of MPPT SEPIC -BUCK Converter Series Using Flower Pollination Algorithm (FPA) - PI Controller in DC Microgrid Isolated System," *2018 International Electrical Engineering Congress (iEECON)*, pp. 1-4, 2018.
- [49] M. Mahmud, S. M. A. Motakabber, A. H. M. Z. Alam, and A. N. Nordin, "Utilizing of Flower Pollination Algorithm for Brushless DC Motor Speed Controller," *2020 Emerging Technology in Computing, Communication and Electronics (ETCCE)*, pp. 1-5, 2020.
- [50] A. Y. Abdelaziz and E. S. Ali, "Static VAR compensator damping controller design based on flower pollination algorithm for a multi-machine power system," *Electric Power Components and Systems*, vol. 43, no. 11, pp. 1268-1277, 2015.
- [51] P. E. Mergos and X. S. Yang, "Flower pollination algorithm parameters tuning," *Soft computing*, vol. 25, no. 22, pp. 14429-14447, 2021.
- [52] S. W. Shneen, H. H. Kareem, and H. A. Abdulmajeed, "Fuzzy-PI control for speed of PMSG drive system," *Journal of Scientific and Engineering Research*, vol. 6, pp. 31-35, 2019.
- [53] A. K. K. Raheem, S. W. Shneen, M. H. Jaber, and A. H. Reja, "Design and Simulation of a Second-Order Universal Switched-Capacitor Filter as a 10-Pin Dual-In-Line Package Integrated Circuit," *Engineering and Technology Journal*, vol. 30, no. 18, pp. 3175-3191, 2012.
- [54] A. E. Kayabekir, G. Bekdaş, S. M. Nigdeli, and X. S. Yang, "A comprehensive review of the flower pollination algorithm for solving engineering problems," *Nature-inspired algorithms and applied optimization*, pp. 171-188, 2018.
- [55] A. Ma'arif and A. Çakan, "Simulation and arduino hardware implementation of dc motor control using sliding mode control," *Journal of Robotics and Control (JRC)*, vol. 2, no. 6, pp. 582-587, 2021.
- [56] I. Suwarno, Y. Finayani, R. Rahim, J. Alhamid, and A. R. Al-Obaidi, "Controllability and Observability Analysis of DC Motor System and

- a Design of FLC-Based Speed Control Algorithm,” *Journal of Robotics and Control (JRC)*, vol. 3, no. 2, pp. 227-235, 2022.
- [57] C. V. Hollot and Y. Chait, “Nonlinear stability analysis for a class of TCP/AQM networks,” *Proceedings of the 40th IEEE Conference on Decision and Control (Cat. No.01CH37228)*, vol. 3, pp. 2309-2314, 2001.
- [58] M. K. Oudah, M. Q. Sulttan, and S. W. Shneen, “Fuzzy type 1 PID controllers design for TCP/AQM wireless networks,” *Indonesian Journal of Electrical Engineering and Computer Science*, vol. 21, no. 1, pp. 118-127, 2021.
- [59] J. Shen, Y. Jing, and T. Ren, “Adaptive finite time congestion tracking control for TCP/AQM system with input-saturation,” *International Journal of Systems Science*, vol. 53, no. 2, pp. 253-264, 2022.
- [60] J. Chen and Y. Jing, “Multiple bottleneck topology TCP/AQM switching network congestion control with input saturation and prescribed performance,” *ISA transactions*, 2022.
- [61] A. Giménez, M. A. Murcia, J. M. Amigó, O. Martínez-Bonastre, and J. Valero, “New RED-type TCP-AQM algorithms based on beta distribution drop functions,” *Applied Sciences*, vol. 12, no. 21, p. 11176, 2022.
- [62] J. Shen, Y. Jing, and G. M. Dimirovski, “Fixed-time congestion tracking control for a class of uncertain TCP/AQM computer and communication networks,” *International Journal of Control, Automation and Systems*, vol. 20, no. 3, pp. 758-768, 2022.
- [63] O. Menacer, A. Messai, and L. Kassa-Baghdouche, “Design and analysis of a proportional-integral controller based on a Smith predictor for TCP/AQM network systems,” *Frontiers of Information Technology & Electronic Engineering*, vol. 23, no. 2, pp. 291-303, 2022.
- [64] S. W. Shneen, A. Z. Salman, Q. A. Jawad, and H. Shareef, “Advanced optimal by PSO-PI for DC motor,” *Indonesian Journal of Electrical Engineering and Computer Science*, vol. 16, no. 1, pp. 165-175, 2019.
- [65] S. Patel, P. Gupta, and G. Singh, “Performance measure of Drop tail and RED algorithm,” *2010 2nd International Conference on Electronic Computer Technology*, pp. 35-38, 2010.
- [66] M. Sagfors, R. Ludwig, M. Meyer, and J. Peisa, “Queue management for TCP traffic over 3G links,” *2003 IEEE Wireless Communications and Networking, 2003. WCNC 2003.*, vol. 3, pp. 1663-1668, 2003.
- [67] A. J. Attiya, Y. Wenyu, and S. W. Shneen, “Compared with PI, Fuzzy-PI and PSO-PI controllers of robotic grinding force servo system,” *TELKOMNIKA Indonesian Journal of Electrical Engineering*, vol. 16, no. 1, pp. 65-74, 2015.
- [68] O. Kennedy, E. Chukwu, O. Shobayo, E. N- Osaghae, I. Okokpujie, and M. Odusami, “Comparative analysis of the performance of various active queue management techniques to varying wireless network conditions,” *International Journal of Electrical and Computer Engineering*, vol. 9, no. 1, pp. 359-368, 2019.